



Loving music

Performance DC

User manual



Black with silver chassis



Silver with black chassis



Silver with silver chassis



Black with black chassis

Made in Germany

Clearaudio electronic[®] GmbH

Spardorfer Str. 150 • D-91054 Erlangen • Tel. +49 9131 40300100 • FAX + 49 9131 40300119
www.clearaudio.de • www.analogshop.de • info@clearaudio.de

©Clearaudio electronic GmbH

Version: 2.4_12.01.2017_E



Loving music

Dear **Clearaudio** customer,

You have purchased a State-Of-The-Art turntable, the *Performance DC*, a world class product of **Clearaudio** electronic GmbH.
Congratulations on your purchase!

The main chassis consists of a complex sandwich of materials: aluminum and HDF material. The powerful and smooth-running DC motor is integrated within and is effectively decoupled by the main chassis.

The motor is hidden beneath the platter and drives the precision machined aluminum sub-platter via a precision machined POM main platter are supported by **Clearaudio's** patented *CMB Ceramic Magnetic Bearing*.

The drive system is operated by four blue illuminated buttons, ergonomically integrated into the front left of the chassis. Almost any commercially available 9 inch tonearm can be fitted by virtue of the easily interchangeable armboards.

Please read this user manual carefully so that you can enjoy all the advantages of your *Performance DC* turntable. All information given will help to generate the best performance and avoid any possible damages.

We hope you will enjoy your new **Clearaudio** *Performance DC* turntable.

Clearaudio electronic GmbH

Please read the warnings before connecting your Performance DC turntable to the mains supply.

WARNINGS

- Don't expose your turntable to rain or humidity.
- Don't handle the mains leads with wet hands.
- Don't place or insert anything into the equipment or through ventilation holes.
- No naked flame sources, such as lighted candles, should be placed on the equipment.

CE-MARKING



The **Clearaudio** *Performance DC* meets the regulations concerning electromagnetic disturbance (EMC) and low-voltage appliances.

COPYRIGHT

Recording und reproduction of any sound-material may require the consent of the creator.
Please acknowledge the information given in the

- Copyright Act 1956,
- Dramatic and Musical Performers Act 1958,
- Performers Protection Acts 1963 and 1972,
- Any more recent legal regulations.



Loving music

Contents

| | |
|-------------------------------|-----------|
| 1. Packaging overview | 4 |
| 2. Setup and operation | 5 |
| 3. Special notes | 12 |
| 4. Technical data | 13 |
| Warranty information | 14 |

1. Packaging overview

The Clearaudio *Performance DC* turntable is delivered in specially designed custom packaging.

Please check the contents according to the following list before you set up your new Clearaudio *Performance DC* turntable.

1. Layer (top):

Top of bearing, belt, fittings and accessories (Quality and warranty card, bearing oil, hex keys) sub-platter, power supply

If ordered as set:
Tonearm and/or pickup

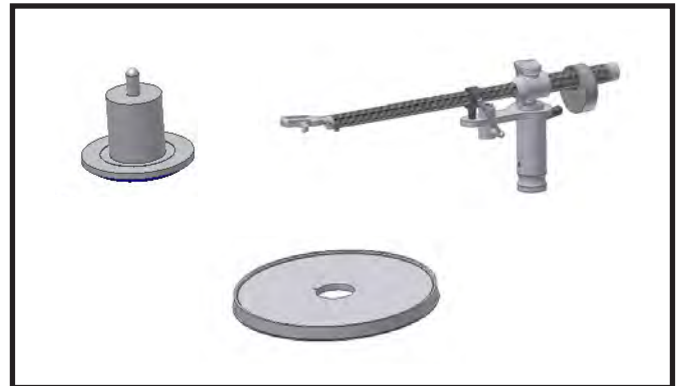

2. Layer (middle):

Turntable chassis



3. Layer (bottom):

Platter



Pic. 1: Packaging overview

IMPORTANT NOTICE: Please double check the tightness of all bolts and armboard mounting hardware, as temperature fluctuations during transit may have caused the hardware to become loose.

2. Setup and operation

The *Performance DC* turntable consists of several components, as described in No 1 (Packaging overview). The setup is easy, as some of the components are pre-assembled at the factory. Please make use of the white gloves enclosed in order to avoid scratches or unwanted fingerprints (e.g. on the platter).

Please follow the instructions step by step:

The *Performance DC* requires a space of at least 16.54 inch x 12.99 inch for positioning.

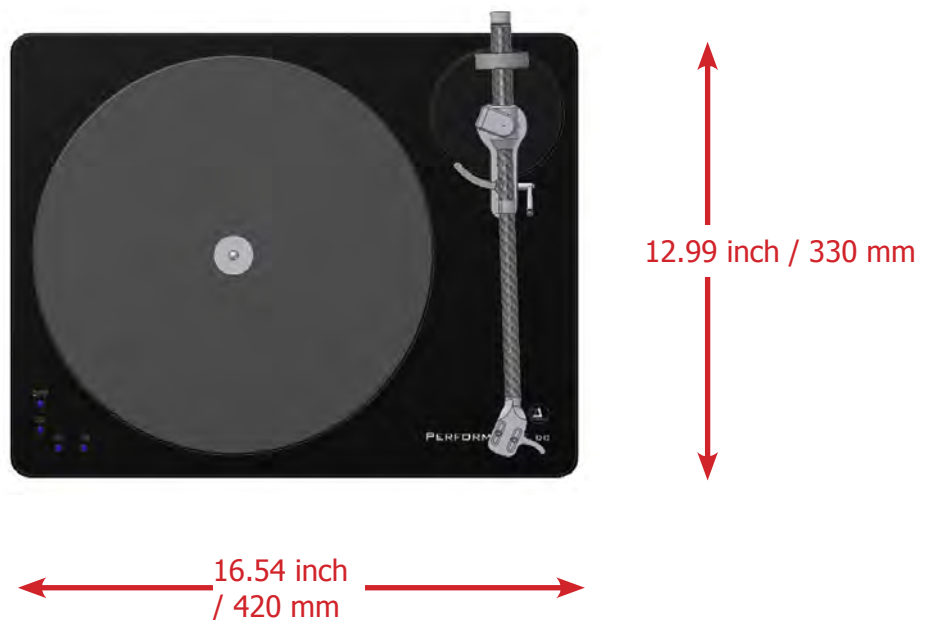

Pic. 2: Setting up space

2.1

Place the pre-mounted chassis on your hifi-rack or another suitable surface.



Pic. 3: Performance DC chassis

2.2

To avoid hum noises it can be necessary to ground the bearing. For that please plug in the provided ground cable into the hole of the screw from the bearing at the bottom side of the turntable.



Pic. 4: Grounding the bearing of the Performance DC

2.3

Please remove the protective seal from the bearing shaft and place two drops of the synthetic bearing oil on the ceramic bearing shaft. Slip the bearing top onto the bearing shaft of the turntable (also available through www.analogshop.de Art. No. AC068).

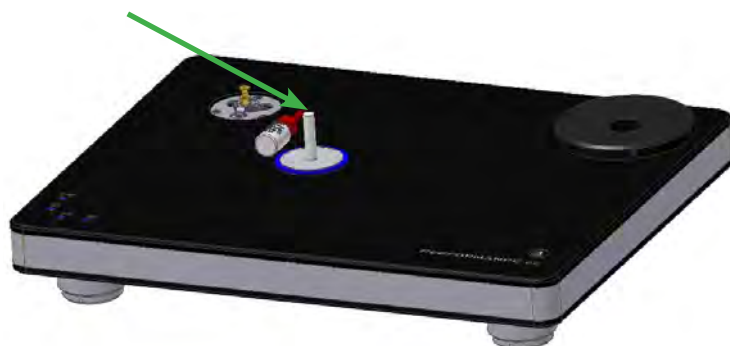

Pic. 5: Bearing oil

2.4

Now you can set the bearing upper part carefully onto the bearing. To avoid damages make sure you slide the bearing upper part slowly and carefully on the polished ceramic shaft.



Pic. 6: Fitting the bearing upper part

2.5

Now you can set the sub-platter carefully onto the bearing (see Pic. 7). To avoid any damage, make sure you slide the sub-platter slowly and carefully onto the bearing.

After that, take the included belt and place it around the motor and the sub-platter (see Pic. 7.1). At this point the sub-platter will be higher than the pulley. This is normal, as the CMB requires the weight of the platter to fully engage it.



Pic. 7: Setting the sub-platter



Pic. 7.1: Placing the belt

2.6

Now you can set the platter carefully onto the bearing. To avoid damage, make sure you slide the platter slowly and cautiously on the sub-platter/ bearing assembly. Hold the platter securely, so the platter does not slip or fall on your turntable.



Pic. 8: Setting the platter onto the bearing

2.7

Please check with the bubble level gauge, if your *Performance DC* turntable is in a level position.

You can adjust each of the turntable's feet to get the turntable level. Only if the turntable is in a level position you will get the best results with your turntable.

Please note:

Through turning the feet clockwise you will raise the turntable, by turning counter clockwise the turntable will lower.



Pic. 9: Adjustment of the level position



Pic. 9.1: Adjustment of the height

2.8

If the *Performance DC* turntable was purchased as a package together with the *Clarify* tonearm, please follow the below described installation of the tonearm.

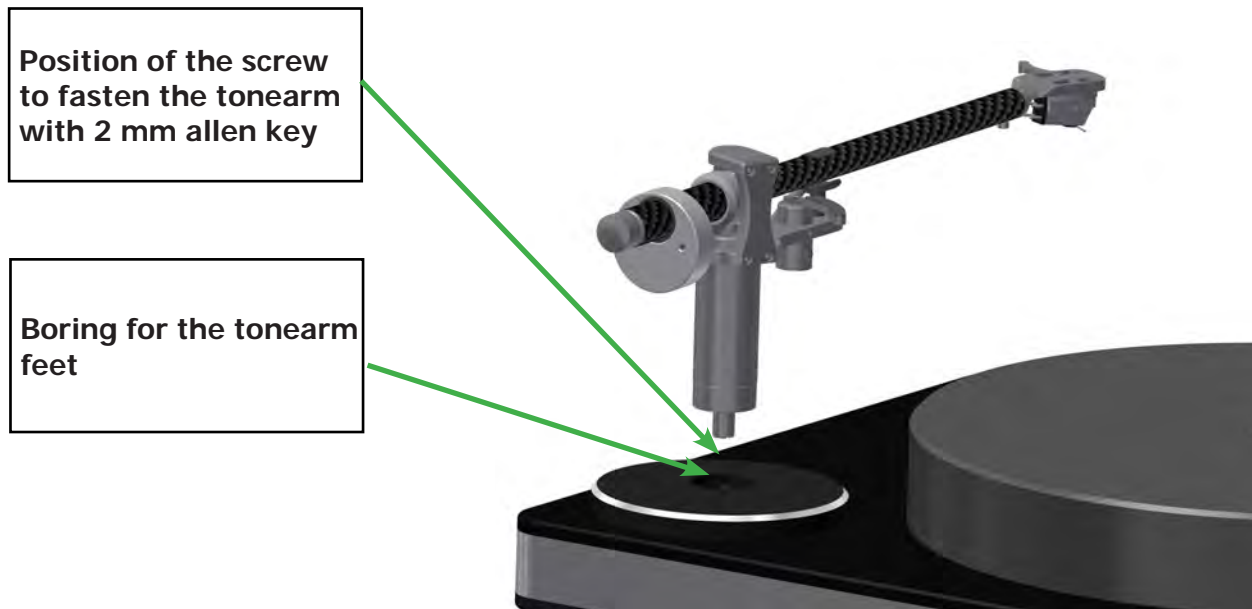

**Position of the screw
to fasten the tonearm
with 2 mm allen key**

**Boring for the tonearm
feet**

Pic. 10: Rear view *Clarify* tonearm

1. Insert carefully first the cable and then the tonearm feet through the hole of the tonearm base.
2. Now adjust the tonearm height.
3. At the end secure the tonearm with the screws with are already integrated at the front of the mounting base.
4. For tonearm and cartridge mounting please refer to the user manual of the respective manufacturer.

If you purchased the **Clearaudio Performance DC** as package with tonearm and cartridge, you received also a Smart Stylus Gauge as accessories, which allows you to adjust the tracking force of the cartridge.

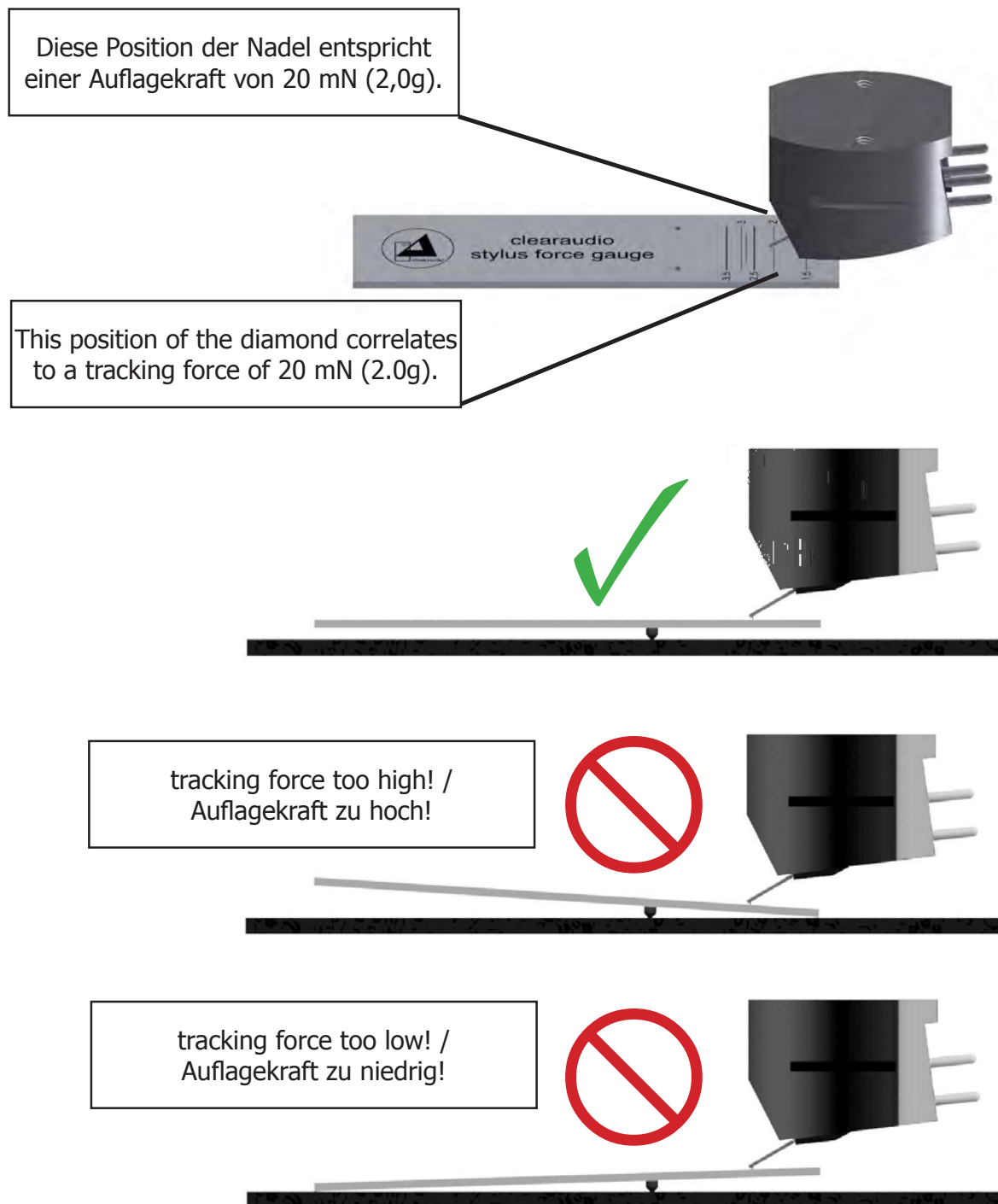

Pic. 11: Use of the Smart Stylus Gauge

Now you can connect the *Performance DC* turntable with the main supply.



Pic. 12: Connection to the main supply

2.9 Speed fine adjustment

As the motor adjustment is already pre-set at the factory, you don't have to check the speed before using the turntable for the first time.

If you want to check the speed of your turntable by yourself over the time, we recommend to use a Stroboscope Testrecord.

To adjust the speed so perfectly and precisely as possible, we recommend the **Clearaudio** Stroboscope Testrecord (Art. No. AC038) and the **Clearaudio** "Speed Light" (Art. No. AC039, both available at www.analogshop.de).

On the backside (close to the power supply input) of your turntable there are three setting trimmers:



- Left trimmer = setting 78 rpm
(near power supply jack)
- Middle trimmer = setting 45 rpm
- Right trimmer = setting 33 1/3 rpm

Pic. 13: Speed fine adjustment

Urgent:

Don't use a metal screw driver. Only use screw driver made out of synthetic or ceramic material, to avoid circuit damage.

Now you are finally ready to play your vinyl records!

Attention:

If the turntable is not in use, disconnect the unit completely from the power supply by removing the main plug from the socket.

We wish you a lot of pleasure with your new *Performance DC* turntable.



3. Special notes

3.1 Maintenance

- If the *Performance DC* turntable is a longer time not in use, please disconnect the motor from the main supply.
- Every two years you can lubricate the bearing of the turntable platter with the delivered oil. In this case it is enough to put 1 or 2 drops of the oil into bearing.
- Please take special caution to any damages of the power cord. Any damages should be repaired only by authorized personal.
A damaged power cord must be exchanged immediately!

Caution!

Please use only non alcoholic fluids and only fluids specially used for acrylic, to clean the *Performance DC* turntable.

Otherwise damage on the material or the surface can occur!

Don't use try cloths for cleaning because of the electrostatic charging. Suitable cleaning fluids will be available at Clearaudio (www.analogshop.de) or your Hifi dealer.

3.2 Transportation

Send / ship the *Performance DC* turntable always and only in the original packing!!!

Only in the original packing Clearaudio can provide the warranty.

If you repackage the turntable, please make all steps inverted like at installation and setup (chapter 2).

- If any transportation of the *Performance DC* turntable should be necessary, please always remove the turntable platter and the shaft holder. Otherwise serious damage can occur!
- To avoid any dust coming into the bearing, the bearing hole needs to be covered as well.

3.3 Service

In case of any necessary, service for all **Clearaudio** products should be done by authorized personal only.

In case of any repair, the **Clearaudio** *Performance DC* turntable needs to be send to your nearest authorized **Clearaudio** distributor, dealer or directly to the Clearaudio factory.

Clearaudio electronic GmbH

Spardorfer Str. 150
91054 Erlangen
Germany

Phone.: +49 9131 40300 100

Fax: +49 9131 40300 119

www.clearaudio.de

www.analogshop.de

info@clearaudio.de

To achieve the full **Clearaudio** warranty (for the *Performance DC* turntable 5 years), it is necessary that you fill out and send the **corresponding part of the warranty registration card back to Clearaudio**, within two weeks after purchase.



4. Technical Data

| | |
|------------------------------------|---|
| Construction details: | Resonance-optimised turntable, highly compressed wood chassis in sandwich construction embedded between two aluminium plates, flat belt driven. |
| Speed change: | Comfortable speed change, 33 1/3 rpm, 45 rpm, 78 rpm (optional) |
| Drive unit: | Decoupled and resonance damped DC motor, drive belt and plug-in power supply unit designed for worldwide use with all networks and power frequencies. |
| Bearing: | Cut and polished ceramic shaft in a sintered bronze bushing, Clearaudio ceramic magnetic bearing (CMB) |
| Platter: | Synthetic material, surface CNC-precision milled, Surface CNC-precision milled, 1.1 inch / 40 mm thickness |
| Speed accuracy (measured): | 0,05% |
| Power consumption: | Max. consumption: 3.3 Watt Consumption in operation: 1.6 Watt Standby mode: < 0.5 Watt Off mode: 0.0 Watt |
| Total weight: | approx. 11 kg |
| Dimensions (W/D/H in inch): | approx. 16.54 x 12.99 x 4.92 (without tonearm) |
| Dimensions (W/D/H in mm): | approx. 420 x 330 x 125 (without tonearm) |
| Warranty: | 5 years* |

* Only if the warranty card is filled out correctly and sent back in time to **Clearaudio**.

Clearaudio electronic is not responsible for typographical errors in descriptions. Technical specifications subject to change or improvement without prior notice. Availability as long as stock lasts.

Copies and imprints- also only in extracts – require written conformation through **Clearaudio** electronic GmbH; Germany

© **Clearaudio** electronic GmbH 2017

Version: October 2017



Loving music

The warranty time for the *Performance DC* turntable is 2 years.

To achieve the full **Clearaudio** warranty of 5 years, it is necessary that you fill out and send the corresponding part of the warranty registration certificate /card back to **Clearaudio**, within two weeks after purchase.

Only if the product is returned in its original packing **Clearaudio** can provide the warranty of 5 years.

ENGLISH **WARRANTY**

For warranty information, contact your local Clearaudio distributor.

RETAIN YOUR PURCHASE RECEIPT

Your purchase receipt is your permanent record of a valuable purchase.

It should be kept in a safe place to be referred to as necessary for insurance purposes or when corresponding with Clearaudio.

IMPORTANT

When seeking warranty service, it is the responsibility of the consumer to establish proof and date of purchase. Your purchase receipt or invoice is adequate for such proof.

FOR U.K. ONLY

This undertaking is in addition to a consumer's statutory rights and does not affect those rights in any way.

FRANÇAIS **GARANTIE**

Pour des informations sur la garantie, contacter le distributeur local clearaudio.

CONSERVER L'ATTESTATION D'ACHAT

L'attestation d'achat est la preuve permanente d'un achat de valeur. La conserver en lieu sûr pour s'y reporter aux fins d'obtention d'une couverture d'assurance ou dans le cadre de correspondances avec clearaudio.

IMPORTANT

Pour l'obtention d'un service couvert par la garantie, il incombe au client d'établir la preuve de l'achat et d'en corroborer la date. Le reçu ou la facture constituent des preuves suffisantes.

DEUTSCH **GARANTIE**

Bei Garantiefragen wenden Sie sich bitte zunächst an Ihren clearaudio-Händler.

Heben Sie Ihren Kaufbeleg gut auf.

WICHTIG!

Die Angaben auf Ihrer Quittung erlauben uns die Identifizierung Ihres Gerätes und belegen mit dem Kaufdatum die Dauer Ihrer Garantie-Ansprüche. Für Serviceleistungen benötigen wir stets die Gerätenummer.

Diese finden Sie auf dem Typenschild auf der Rückseite des Gerätes oder auf dem Tonarm sowie in der beigefügten Garantie-Registrierkarte.

NEDERLANDS **GARANTIE**

Voor inlichtingen omtrent garantie dient u zich tot uw plaatselijke clearaudio.

UW KWITANTIE, KASSABON E.D. BEWAREN

Uw kwitantie, kassabon e.d. vormen uw bewijs van aankoop van een waardevol artikel en dienen op een veilige plaats bewaard te worden voor evt. verwijzing bijv. in verband met verzekering of bij correspondentie met clearaudio.

BELANGRIJK

Bij een evt. beroep op de garantie is het de verantwoordelijkheid van de consument een gedateerd bewijs van aankoop te tonen. Uw kassabon of factuur zijn voldoende bewijs.

ITALIANO **GARANZIA**

L'apparecchio è coperto da una garanzia di buon funzionamento della durata di un anno, o del periodo previsto dalla legge, a partire dalla data di acquisto comprovata da un documento attestante il nominativo del Rivenditore e la data di vendita. La garanzia sarà prestata con la sostituzione o la riparazione gratuita delle parti difettose.

Non sono coperti da garanzia difetti derivanti da uso improprio, errata installazione, manutenzione effettuata da personale non autorizzato o, comunque, da circostanze che non possano riferirsi a difetti di funzionamento dell'apparecchio. Sono inoltre esclusi dalla garanzia gli interventi inerenti l'installazione e l'allacciamento agli impianti di alimentazione.

Gli apparecchi verranno riparati presso i nostri Centri di Assistenza Autorizzati. Le spese ed i rischi di trasporto sono a carico del cliente. La casa costruttrice declina ogni responsabilità per danni diretti o indiretti provocati dalla inosservanza delle prescrizioni di installazione, uso e manutenzione dettagliate nel presente manuale o per guasti dovuti ad uso continuato a fini professionali.

ESPAÑOL **GARANTIA**

Para obtener información acerca de la garantía póngase en contacto con su distribuidor clearaudio.

GUARDE SU RECIBO DE COMPRA

Su recibo de compra es su prueba permanente de haber adquirido un aparato de valor. Este recibo deberá guardarlo en un lugar seguro y utilizarlo como referencia cuando tenga que hacer uso del seguro o se ponga en contacto con clearaudio.

IMPORTANTE

Cuando solicite el servicio otorgado por la garantía el usuario tiene la responsabilidad de demostrar cuándo efectuó la compra. En este caso, su recibo de compra será la prueba apropiada.